

OPC-02 Outdoor Protective Cover for SC-01 strain sensor

General information

- ▲ Great outdoor protection against rain, water splashes, direct sunlight, animals, ...
- ▲ Temperature and UV resitive
- ▲ Several mounting alternatives (chemical installation or bolts)
- ▲ Robust, reliable, and lightweight concept.

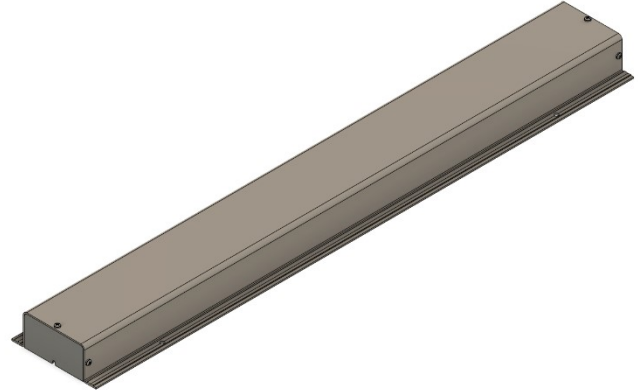

Basic characteristics

- ▲ Metallic or white color
- ▲ PVC material - UV stabilized or stainless steel 1.4301
- ▲ Minamalist dimmensions
- ▲ IP 66 or IP 67¹⁾ protection
- ▲ Wide temperature range -20 to +70°C
- ▲ Inner insulation: Neoprene
- ▲ Cable isolation: self-isolating design (does not require additional elements on the cable such as gland - the cable is squeezed down between the flange of the cover and the surface of the object on which the sensor is installed).

Physical properties

Material	PVC, 1.4301
Protection grade	IP 44 / IP 66 ¹⁾
Dimensions (L x W x H)	750 (variable) x 120 x 45mm
Compatible sensors	SC-01, MSA-01, and SC-01/T
Weight	Approximately 25g + 1400g x GL ²⁾

¹⁾ Additional materials such as "silicone" sealant are required to achieve the best performance.

²⁾ Gauge the length of the sensor in meters [m].

Packaging

Typically integrated into the sensor packaging / Included in the sensor's cardboard box

Quality statement

All products are 100% tested and calibrated at SYLEX
 All products are manufactured according to ISO 9001:2015 and ISO 14001:2015

OPC-02 Outdoor Protective Cover for SC-01 strain sensor

Installation remarks

The OPC-02 is possible to be installed above the sensor using bolts, as shown in Figure 1, and either by using 4x bolts or any suitable adhesive, that will ensure reliable connection of the cover to the surface. We recommend using standard metric bolts with the size of M5 for the installation.

Figure 1 shows the position of the mounting holes on the OPC-02 cover, and the position of the entry/exit points of the cable. The cover features internal insulating foam that is not shown in this picture.

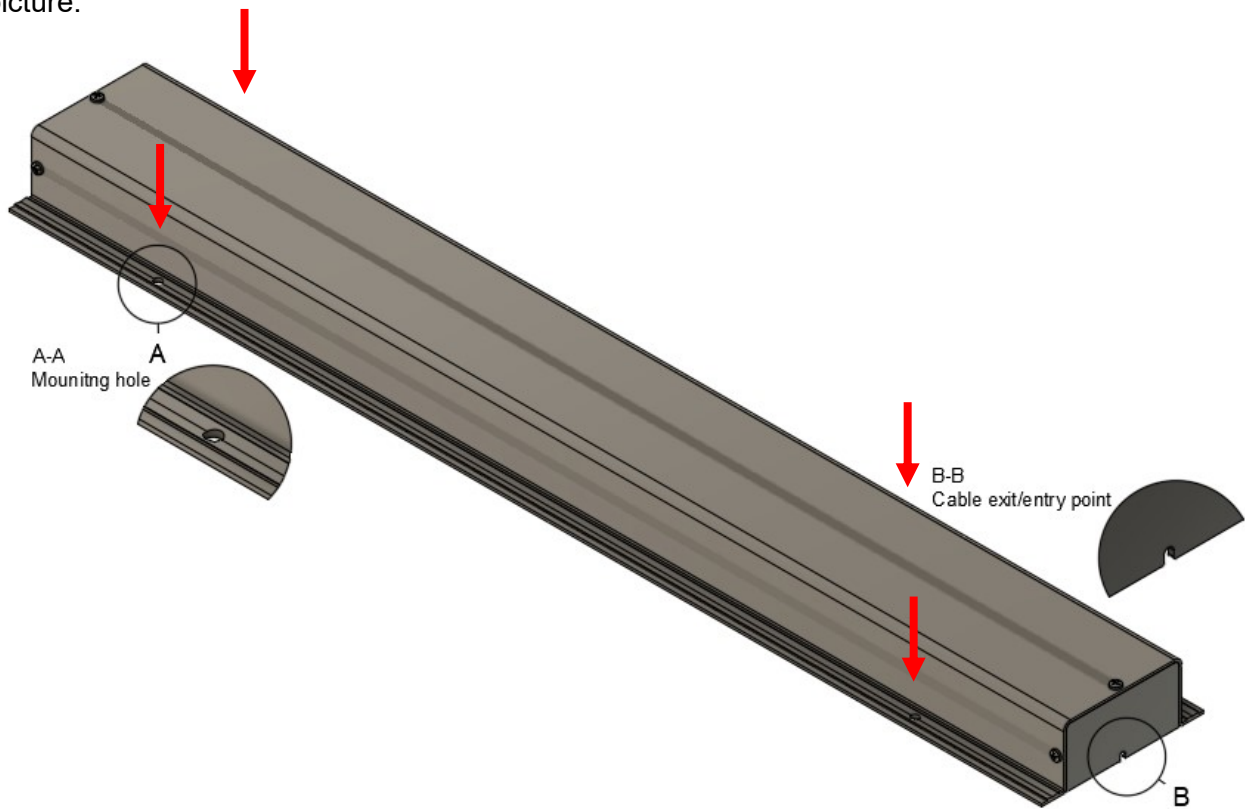

Figure 1: Installation possibilities of the OPC-02 protection cover.

For more information contact our sales team at sales@sylex.sk

* Specifications are subject to change without notice