

SWS-03 Spot-weldable strain sensor

Basic characteristic

- ▲ SWS-03 is a short gauge spot-weldable strain sensor measuring strain changes in $\mu\epsilon$ or extensions (elongation) in μm .
- ▲ SWS-03 can be connected in a series configuration.

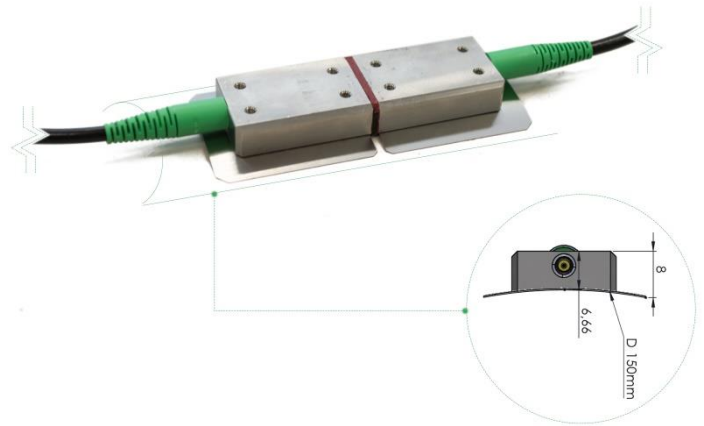

Benefits

- ▲ Surface-mountable using spot-welding, or gluing to the surface.
- ▲ Adjustable pre-strain during installation.

Applications

- ▲ Strain changes detection
- ▲ Steel deformations, etc...
- ▲ Can be mounted on different surfaces including pipelines, walls, etc.

Performance properties

Strain range ¹⁾	$\pm 1500\mu\epsilon$
Accuracy (guaranteed) ²⁾	$< 0.5\% \text{ FS}^4$
Accuracy (typical) ²⁾	$< 0.23\% \text{ FS}^4$
Precision (guaranteed) ³⁾	$< 0.25\% \text{ FS}^4$
Precision (typical) ³⁾	$< 0.15\% \text{ FS}^4$
Strain sensitivity	$1,2\text{pm}/\mu\epsilon$
Operating Temperature range	-20°C to $+60^\circ\text{C}$
Ingress Protection rating	IP 67

¹⁾ The strain range is possible to extend to $\pm 2000\mu\epsilon$

²⁾ Accuracy is established for each sensor under laboratory conditions and it includes hysteresis, non-linearity, and repeatability of the sensor

³⁾ Precision is established on a batch basis and it includes hysteresis, non-linearity, repeatability, and reproducibility of the sensor.

⁴⁾ FS: full-scale range

SWS-03 Spot-weldable strain sensor

Physical properties

Housing material	SS316L – 1.4404
Anchoring distance	Not applicable
Dimensions (without cable) ¹⁾	65 x 28 x 8 mm
Weight (without cable)	68g
Cable type	3mm Dyneema reinforced cable
Cable length ²⁾	1mtr
Cable Bend Radius (dynamic)	40mm
Cable Bend Radius (static)	30mm
Connector type ³⁾	FC/APC
Mounting method	Glue or spot welding

¹⁾ For further dimensions details see the product drawing

²⁾ Cable length is extendable on request

³⁾ Other connector types available on request

Packaging

Cardboard box with dimensions: 370x290x45mm¹⁾

Quality statement

SWS-03 is compliant with IEC 61757-1-1:2016/Ed1.0 and IEC 61757:2018
 All sensors are 100% tested and calibrated at SYLEX
 The sensor is manufactured according to ISO 9001:2008 and ISO 14001:2004

Optional accessories

- ▲ **PST-02 Pre-strain setup installation dial tool** – used for pre-strain set up during the installation.
- ▲ **WCP-01 Watertight connector protection** – used for FC/APC connector protection during the installation against dust and water – IP67 rated.
- ▲ **LCP-03 Longer cable pigtails** – used to extend the cable lengths from 1mtr up to 20mtr.

¹⁾ Every sensor is equipped with a Transportation fixture, see Annex 1: SWS-03 Transportation fixture.

SWS-03 Spot-weldable strain sensor

Annex 1: SWS-01 Transportation fixture

SWS-01 comes with preinstalled Transportation fixture – this is to protect the sensor during transportation and initial manipulation. This transportation fixture needs to be removed from the sensor before installation.

Remove the screws and top plate from SWS-01 as shown in Figure 2 – follow the alphabetical order of all parts as listed in Figure 1. All tools are included inside the PST-01 package.

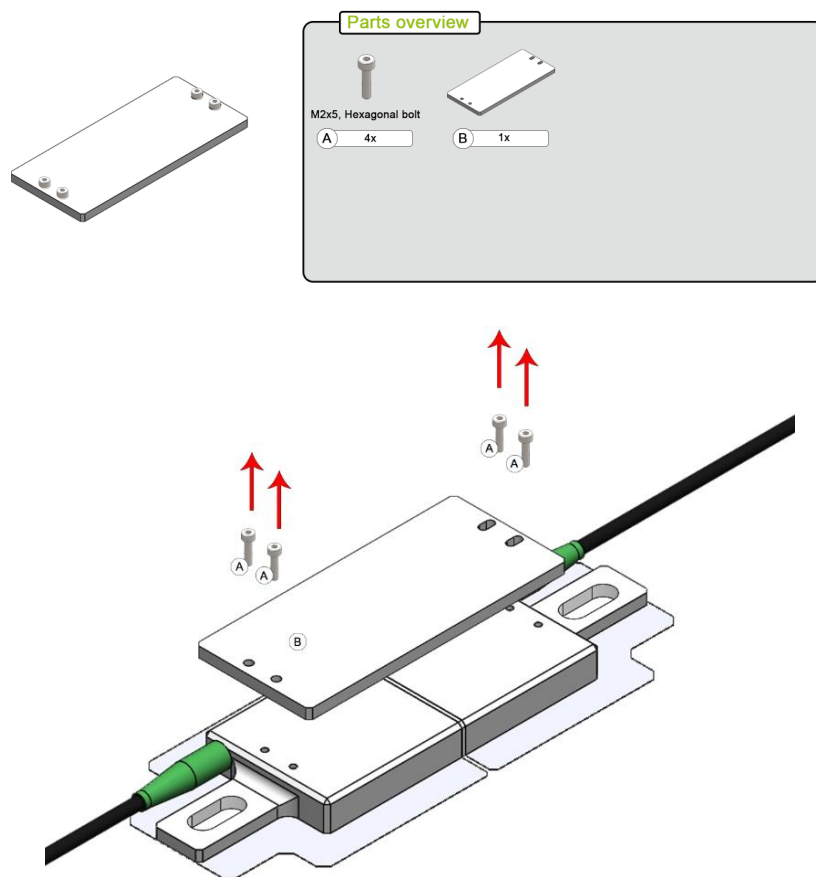

Annex 2: PST-03 Pre-strain tool for SWS-03

PST-03 is a reusable tool to set up pre-strain on the SWS-03. Because it is a reusable item, it is ordered separately and is not a standard part of the SWS-01 sensor.

PST-03 provides safely pre-straining the SWS-03 sensor up to 4000 $\mu\epsilon$.

See more information in PST-03 Datasheet or SWS-02 Installation procedure.

For more information contact our sales team at sales@sylex.sk

* Specifications are subject to change without notice