

Standard version:

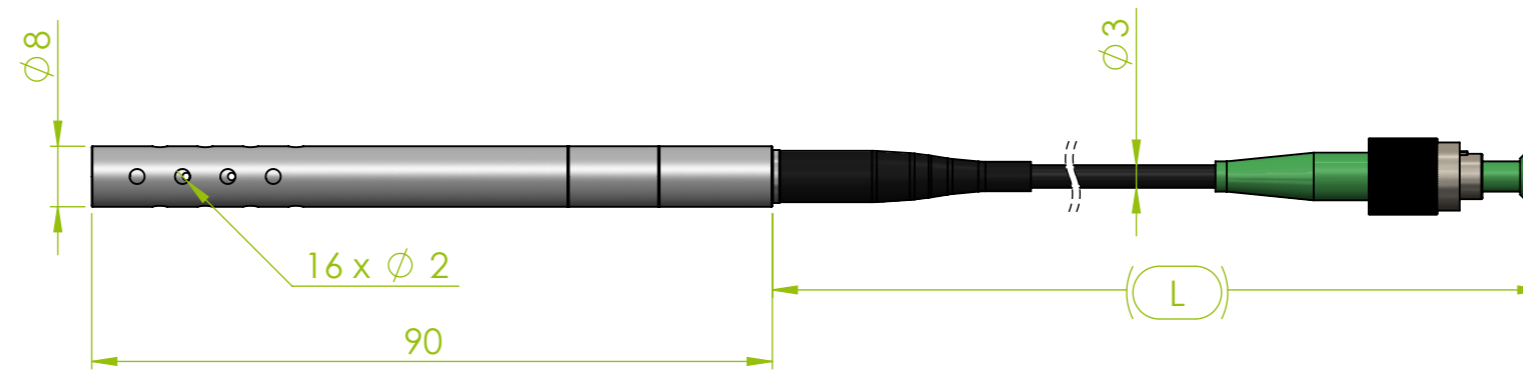

3D View:
Scale: 1:1

Optional accessories:

- LCP-03 Longer Dyneema cable pigtail with 1x WSP-02 (Watertight Splice Protection) and with 1x WCP-01 Watertight Connector Protection 1x FC/APC IP67:

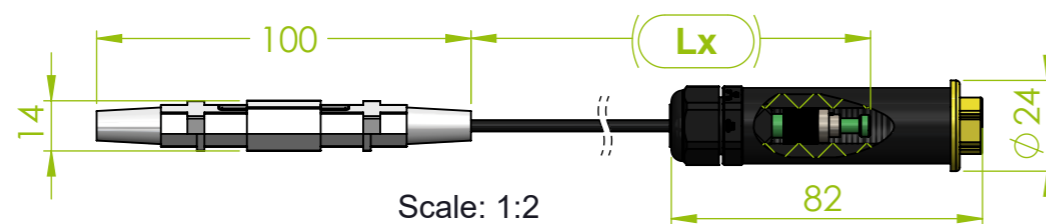

Parameter	Length	Tolerance
L	1000 mm (standard)	±50 mm
Lx	Optional: Custom-Defined Length	±xx mm

TITLE: HS-01 Humidity sensor			
REVISION: A	SCALE: 1:1	DRAWN BY, DATE: Filip Klema 02.03.2023	
	STATUS: Approved by	CHECKED BY, DATE: Branislav Pikus 16.05.2023	
	DIMENSIONS IN MM (UNLESS SPECIFIED)	APPROVED BY, DATE: Tomáš Salát 16.05.2023	
NAME OF CAD FILE: HS-01	PRODUCT NUMBER: F-HSX-001-xxx-xxx/xx/xxxx	DRAWING NUMBER: HS-01	SHEET No: 1 of 1
THIS DRAWING CONTAINS INFORMATION THAT IS PROPERTY OF SYLEX s.r.o AND SHOULD NOT BE USED WITHOUT WRITTEN PERMISSION			SIZE A3