

Standard version:

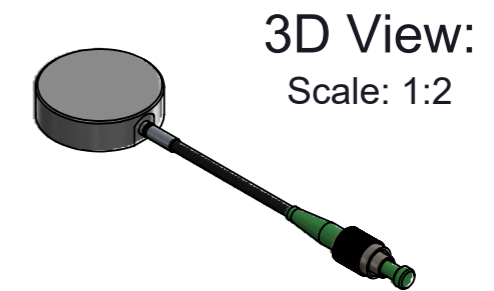

Optional accessories:

- LCP-03 Longer Dyneema cable pigtail with 1x WSP-02 (Watertight Splice Protection) and with 1x WCP-01 Watertight Connector Protection 1x FC/APC IP67:

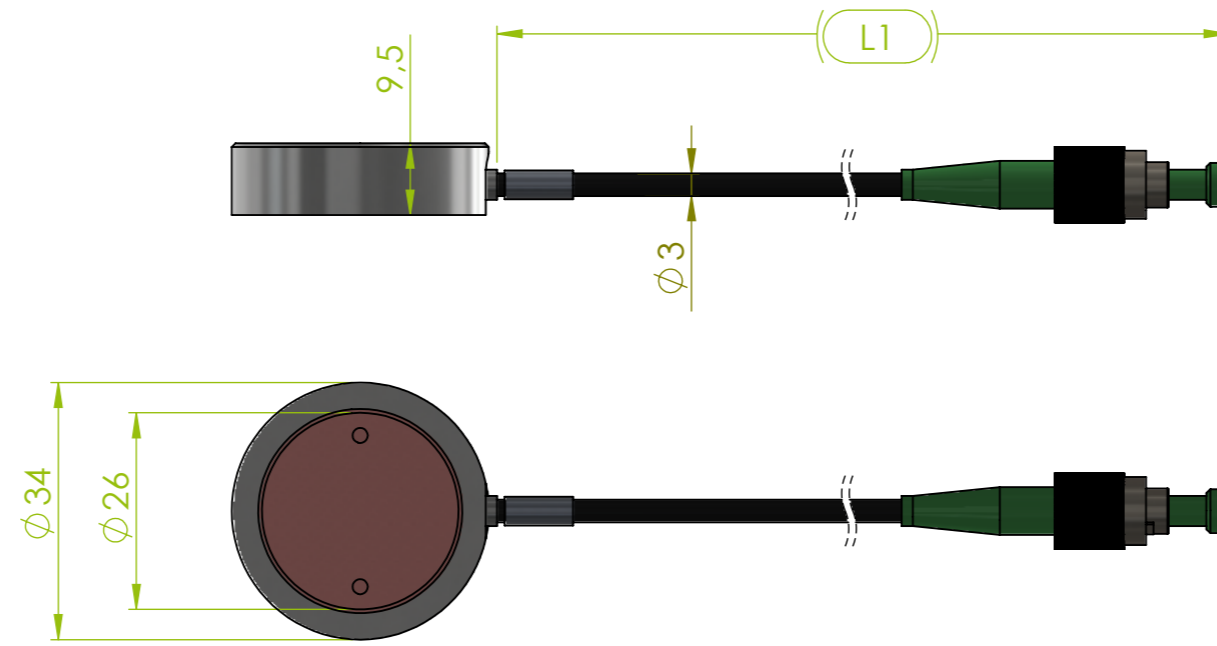
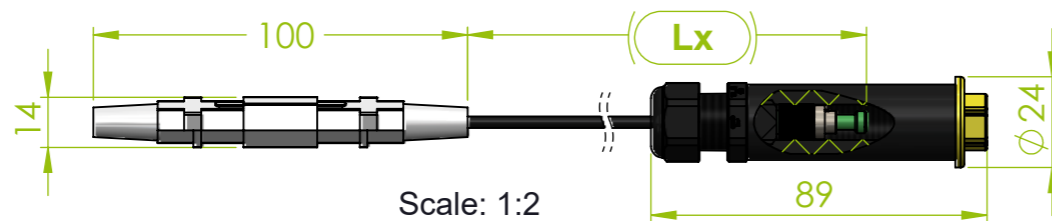

Parameter	Length	Tolerance
L1	1000 mm (standard)	±50 mm
L2	NA	±xx mm
Lg	NA	±xx mm
Lx	Optional: Custom-Defined Length	±xx mm

TITLE: STS-03 Surface temperature sensor			
REVISION: 0	SCALE: 1:1	DRAWN BY, DATE: Branislav Pikus 24.04.2018	
	STATUS: InWork	CHECKED BY, DATE: Branislav Pikus 24.04.2018	
	DIMENSIONS IN MM (UNLESS SPECIFIED)		
NAME OF CAD FILE: STS-03 WEB		PRODUCT NUMBER: F-ST5-003-xxx-xxx/xx/xxxx	DRAWING NUMBER: STS-03 WEB
THIS DRAWING CONTAINS INFORMATION THAT IS PROPERTY OF SYLEX s.r.o AND SHOULD NOT BE USED WITHOUT WRITTEN PERMISSION			SHEET No: 1 of 1
			SIZE A3